

VERTICUS 5 INDUSTRY

The Compressor System for Air and Nitrogen

- › 85 – 1980 l/min
- › 25 – 500 bar

- › FOR MEDIUM AND HIGH PRESSURE
- › PROVEN RELIABILITY
- › WIDE VARIETY OF USES



The heavy duty system with excellent reliability for compressing air and nitrogen.

The BAUER B-CONTROL combines fully automatic start-stop-operation with maximum user confidence.

The optional BAUER purification systems offers high gas and air purity.

Units available in standard open or Super Silent version.

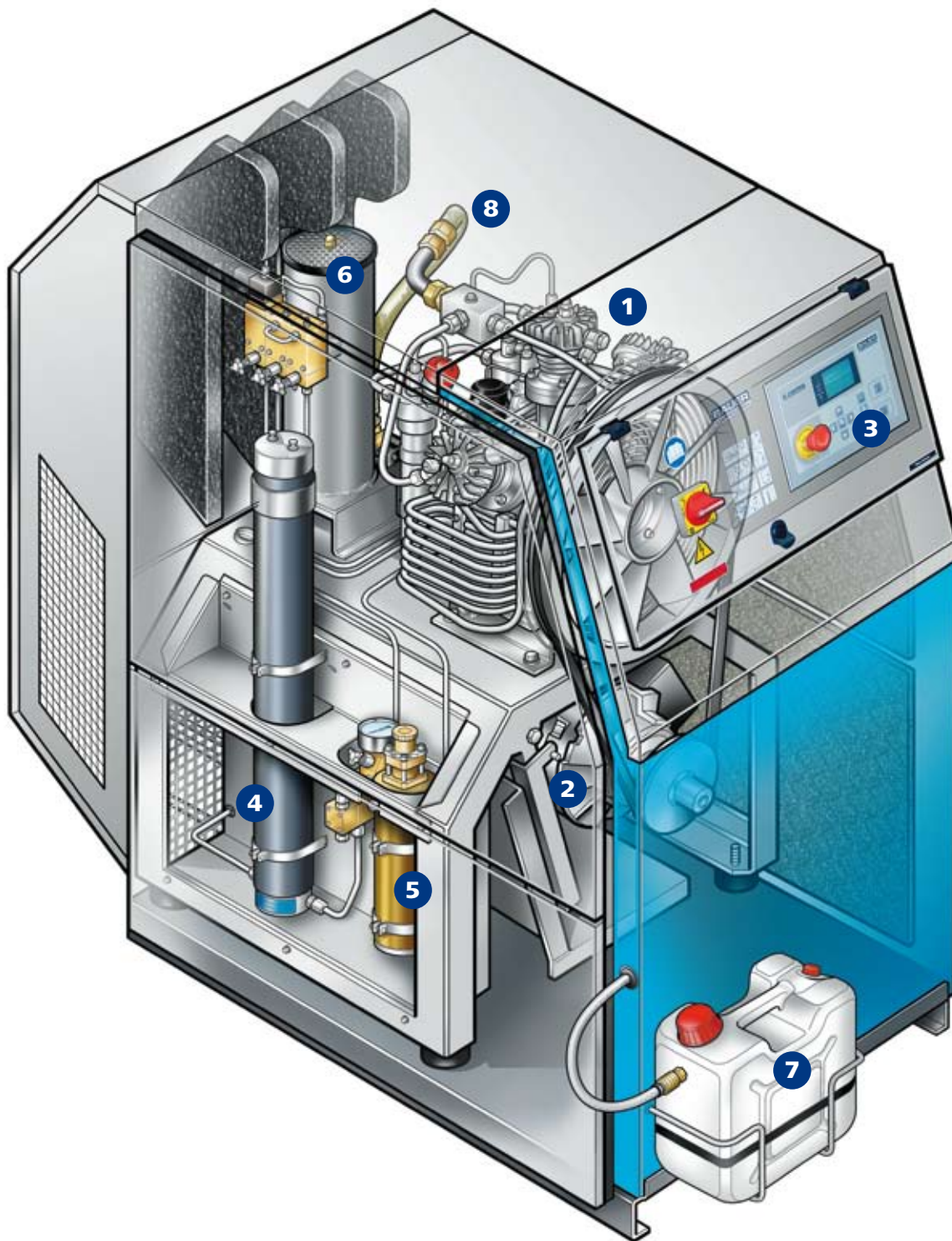

- 1** COMPRESSOR BLOCK
- 2** 3-PHASE MOTOR
- 3** COMPRESSOR CONTROL
- 4** FILTER SYSTEM P 61 / P 81
- 5** OIL AND WATER SEPARATOR
- 6** SSC CONDENSATE DRAIN SYSTEM
- 7** CONDENSATE COLLECTING TANK
- 8** GAS INTAKE (GI / GIB VERSION)

Compress without compromise

THE UNIT CONCEPT

Modular-unit-concept to make an easy upgrade your compressor with filter systems, extended control and noise control.

- › The construction and configuration ensures that installation doesn't require a special foundation.
- › Optional: Up to two high pressure storage cylinders mounted on a single base frame.

COMPRESSOR BLOCK

At the heart of the compressor system, the proven and tested BAUER compressor block guarantees reliability and maximum economy in service.

- › Indestructible industrial roller bearings suited for continuous operation during 30,000 operating hours and more.
- › Hardened, plasma nitrated cylinders with a special plateau honing for minimum oil consumption and abrasion of moving parts.
- › Because of the well engineered cooling air circulation in the compressor housing and with an inter-cooler after every stage, optimum heat dissipation is guaranteed.
- › Virtually zero wear piston rings made of high-tech plastics in the high pressure final stage.
- › Maintenance-free low pressure oil pump with oil filter for a reliable lubrication and longevity of the block.



4-stage high pressure compressor block K150

FILTER SYSTEM P 61 UND P 81

High pressure nitrogen or air applications require dry and clean gas and air to protect customers downstream system from impurities.

- › With the BAUER high pressure filter systems P 61 and P 81 a pressure dew point of $\leq -20^{\circ}\text{C}$ and a residual oil concentration of $\leq 0,25 \text{ ppm}_w$ can be reached. This is according to industry air standard DIN EN ISO 8573-1: oil content class 3, humidity class 3.
- › The optional SECURUS (only for high pressure units) continuously controls the saturation (humidity) and displays this at the compressor control.



BAUER B-CONTROL

B-CONTROL COMPRESSOR CONTROL

For fully automatic operation of the unit:

- › Free programmable acc. to customer's requirements.
- › Fully automatic, monitoring of all necessary compressor data.
- › Optional: CANBUS interface allows interconnected operation and integration in higher-ranking control systems.
- › Optional: PROFIBUS/MODBUS.
- › Optional: B-MESSENGER to transfer data to mobile phones, computers or to a fax. The B-REMOTE is for visualization and remote maintenance for the compressor units.

SUPER SILENT ENCLOSURE

For critical locations where noise reduction is mandatory.

- › All compressor units of the industrial VERTICUS 5 range are available in standard open or Super Silent version.
- › Thanks to the modular concept open units can be upgraded to Super Silent compressors in next to no time.

Technical Data

Model	F.A.D. ¹⁾		Number of stages	Speed	Motor	Power consumption	Net weight approx.
	l/min	m ³ /h					
B (BGI) - Range, 30 - 63 bar / 400 - 900 psig							
B (BGI) 12.4 - 4 - 5	215	13	3	1420	4	3,5	345
E (EGI) - Range, 63 - 75 bar / 900 - 1100 psig							
E (EGI) 12.4 - 2,2 - 5	130	7,8	3	900	2,2	2	335
E (EGI) 12.4 - 3 - 5	170	10,2	3	1150	3	2,7	340
E (EGI) 12.4 - 4 - 5	215	13	3	1420	4	3,7	345
E (EGI) - Range, 75 - 90 bar / 1100 - 1300 psig							
E (EGI) 100 - 3 - 5	140	8,4	3	1350	3	2,7	335
E (EGI) 120 - 4 - 5	215	13	3	1420	4	3,7	345
I (GI) - Range, 90 - 350 bar / 1300 - 5000 psig							
I (GI) 100 - 3 - 5	85	5,1	3	900	3	2,2	335
I (GI) 100 - 4 - 5	125	7,5	3	1270	4	3,3	340
I (GI) 120 - 4 - 5	170	10,2	3	1200	4	3,7	345
I (GI) 120 - 5,5 - 5	215	13	3	1470	5,5	4,7	355
I (GI) 12.14 - 7,5 - 5	300	18	4	1470	7,5	6,5	365
I (GI) 15.1 - 7,5 - 5	340	20,4	4	1050	7,5	6,9	440
I (GI) 15.1 - 11 - 5	420	25,2	4	1320	11	9,6	450
I (GI) 150 - 11 - 5	500	30	4	1230	11	10,2	450
I (GI) 180 - 15 - 5	610	36,6	4	1320	15	12	470
I (GI) - Range, 350 - 500 bar / 5000 - 7200 psig							
I (GI) 15.11 - 7,5 - 5	310	18,6	4	960	7,5	7	440
I (GI) 15.11 - 11 - 5	420	25,2	4	1320	11	10,4	450
I (GI) 18.1 - 15 - 5	550	33	5	1320	15	12,4	470

Model	Intake pressure	F.A.D. ¹⁾		Number of stages	Speed	Power consumption
		bar(g)	l/min			
BOOSTER GIB, 90 - 350 bar / 1300 - 5000 psig						
GIB 12.2 - 5,5 - 5	5 - 11	200 - 475	12 - 28,5	2	1230	3,3 - 5,1
GIB 15.3 - 11 - 5	7 - 10	510 - 750	30,6 - 45	2	1140	6,6 - 8,2
GIB 15.4 - 15 - 5	2 - 4	450 - 750	27 - 45	3	1320	7,6 - 11,3
BOOSTER BGIB, 25 - 50 bar / 360 - 700 psig						
BGIB 12.3 - 5,5 - 5	5 - 10	465 - 1550 ²⁾	18 - 93	1	1300	3,1 - 5,4
BGIB 12.3 - 7,5 - 5	10 - 13	1530 - 1980 ²⁾	91,8 - 118,8	1	1300	4,7 - 6,3

1) acc. to VDMA 4362, measured with flow meter at 0,8 factor of final pressure (±5%)

2) Maximum capacity according to the combination of intake and final pressure

BAUER KOMPRESSOREN GmbH
P.O. Box 710260 | 81452 München
Phone +49(0)89/78049-0
Fax +49(0)89/78049-167
info@bauer-kompressoren.de
www.bauer-kompressoren.de



DIN EN ISO 9001

VERTICUS LUFT-N2-E
9.08 PR 0147
Subject to technical modifications